

NAXSOLUX

Rated Current	I_n [A]	25	40	63
Dimensions	mm	50 x 18	50 x 18	50 x 18
Rated operational voltage	U_e [V]	400	400	400
Rated insulation voltage	U_i [V]	690	690	690
Frequency	f [Hz]	50/60	50/60	50/60
Rated short time withstand current (1s)	I_{cw} [kA] _{RMS}	3	3,3	3,6
Peak Current	I_{pk} [kA]	4,5	5	5,4
Phase resistance at 20°C	R_{20} [mΩ/m]	6,19	2,96	2,31
Phase reactance (50Hz)	X_1 [mΩ/m]	1,3	0,62	0,49
Phase impedance	Z_1 [mΩ/m]	8,15	3,9	3,04
Phase resistance at thermal conditions	R_1 [mΩ/m]	8,05	3,85	3
Pe resistance	R_{PE} [mΩ/m]	1,32	1,32	1,32
Fault loop resistance phase/N	R_{FN} [mΩ/m]	14,24	6,81	5,31
Fault loop reactance phase/N	X_{FN} [mΩ/m]	1,3	0,62	0,49
Fault loop impedance phase/N	Z_{FN} [mΩ/m]	14,3	6,84	5,34
Fault loop resistance phase/PE	R_{FPE} [mΩ/m]	8,26	4,71	3,99
Fault loop reactance phase/PE	X_{FPE} [mΩ/m]	1,89	1,08	0,91
Fault loop impedance phase/PE	Z_{FPE} [mΩ/m]	8,47	4,83	4,1
Voltage Drop with distributed load	ΔV [V/m/A] $10^{-3} \cos \varphi = 0,70$	5,68	2,72	2,12
	ΔV [V/m/A] $10^{-3} \cos \varphi = 0,75$	5,97	2,86	2,23
	ΔV [V/m/A] $10^{-3} \cos \varphi = 0,80$	6,25	2,99	2,33
	ΔV [V/m/A] $10^{-3} \cos \varphi = 0,85$	6,52	3,12	2,43
	ΔV [V/m/A] $10^{-3} \cos \varphi = 0,90$	6,76	3,23	2,52
	ΔV [V/m/A] $10^{-3} \cos \varphi = 0,95$	5,44	2,6	2,6
	ΔV [V/m/A] $10^{-3} \cos \varphi = 1,00$	6,97	3,33	2,6
Weight	ρ [kg/m]	0,65	0,7	0,77
Degree of protection	IP	41/55	41/55	41/55
Losses for the joule effect at rated current	P [W/m]	5	6	12
Temperature range		-5° + 40°	-5° + 40°	-5° + 40°

ALL THESE PRODUCTS ARE COMPLIANCE TO STANDARDS IEC 60439 -1 and 2
 ALL THESE PRODUCTS HAVE BEEN CERTIFIED AT IMQ INSTITUTE IN MILAN

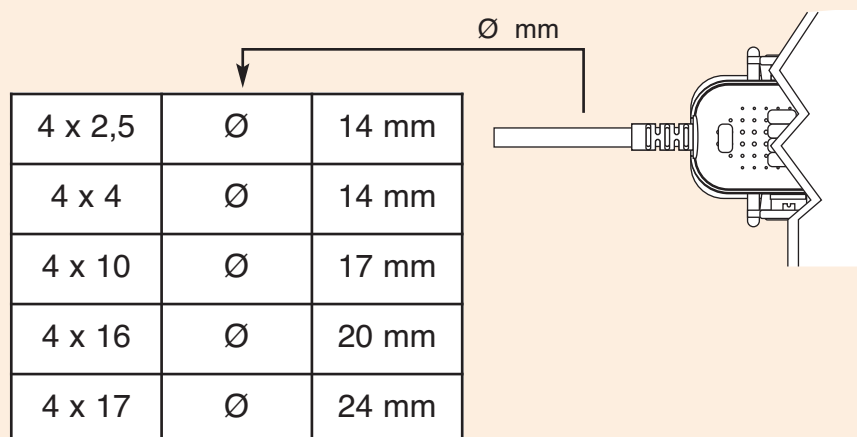

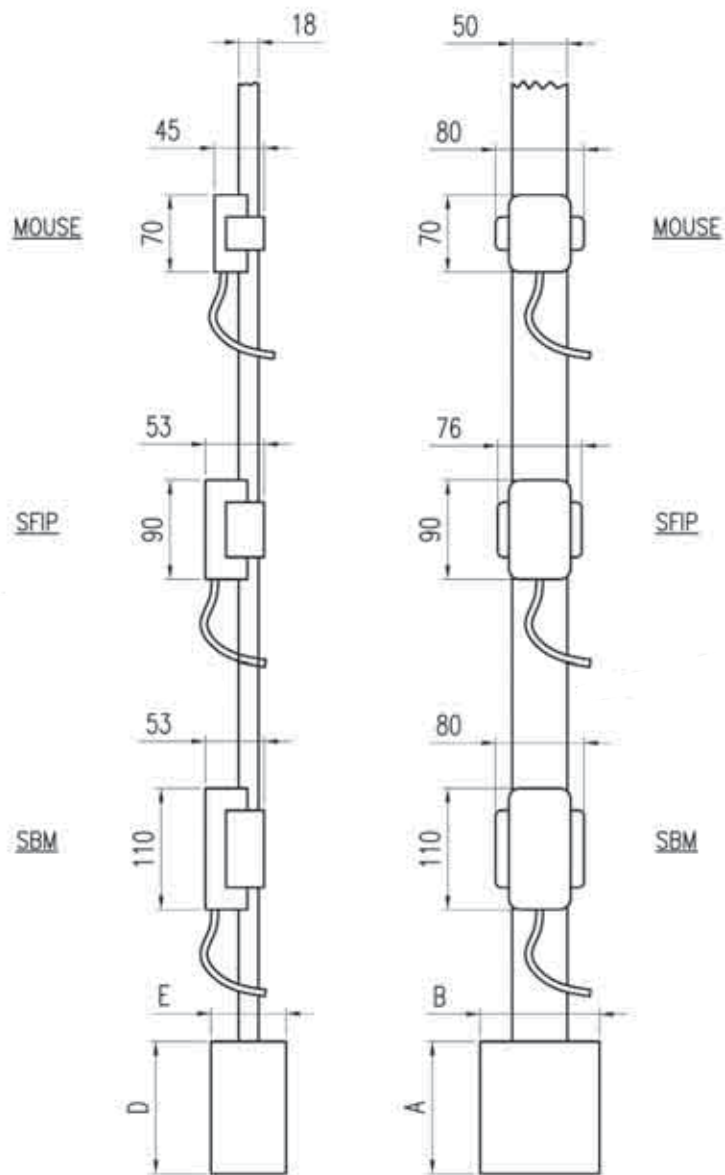









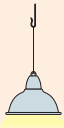

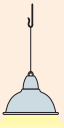

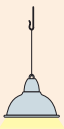

ATSX 25 AxB 85x62
 ATDX 25 AxB 82x62

ATSX 25 DxE 85x42
 ATDX 25 DxE 82x42

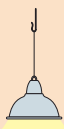
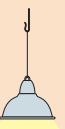
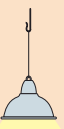
ATSX 40 AxB 200x120
 ATDX 40 AxB 200x120

ATSX 40 DxE 200x70
 ATDX 40 DxE 200x70

							
	1 x 250 Jodur	1 x 250 sodium	1 x 150 sodium	1 x 36	1 x 58	2 x 36	2 x 58
25A 1P + N+T	A = 10 B = 8	A = 8 B = 7	A = 20 B = 16	A = 60 B = 50	A = 50 B = 40	A = 40 B = 35	A = 25 B = 20
40A 1P + N+T	A = 20 B = 18	A = 14 B = 12	A = 30 B = 25	A = 90 B = 70	A = 70 B = 60	A = 50	A = 45
							
	1 x 400 Jodur	1 x 400 sodium					
25A 1P + N+T	A = 9 B = 8	A = 6 B = 5					
40A 1P + N+T	A = 16 B = 14	A = 10					

							
	1 x 250 Jodur	1 x 250 sodium	1 x 150 sodium	1 x 36	1 x 58	2 x 36	2 x 58
25A 3P + N+T	A = 24 B = 20	A = 16 B = 14	A = 40 B = 35	A = 150 B = 120	A = 120 B = 100	A = 100 B = 80	A = 60
40A 3P + N+T	40	28	60	200	160	120	110
							
	1 x 400 Jodur	1 x 400 sodium					
25A 3P + N+T	A = 18 B = 16	A = 12 B = 10					
40A 3P + N+T	A = 32 B = 28	A = 20 B = 16					

25A MAX 100 MT 40A MAX 140 MT

25A 1P + N + T = 100 % RATING

25A 3P + N + T = 100 % RATING

40A 1P + N + T = 100 % RATING

40A 3P + N + T = 100 % RATING

25A 5P + N + T = 25A 3P + N + T = 100 % RATING + 25A 1P + N + T = 80 % RATING (2 x 25A + 1 X 20A)

40A 5P + N + T = 40A 3P + N + T = 100 % RATING + 40A 1P + N + T = 80 % RATING (2 x 40A + 1 X 32A)

25A 1P + N + T + 25A 1P + N + T = 90% RATING (2 X 20A)

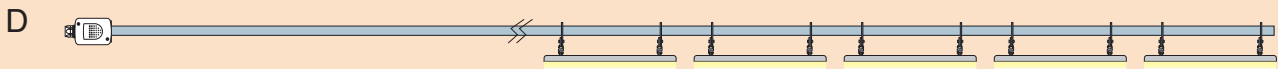
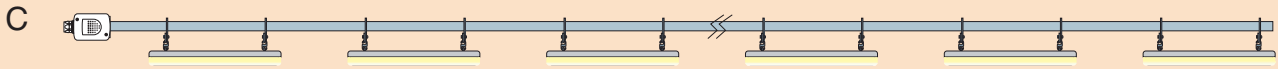

A= 100% B= 70% C= 100% D= 80%

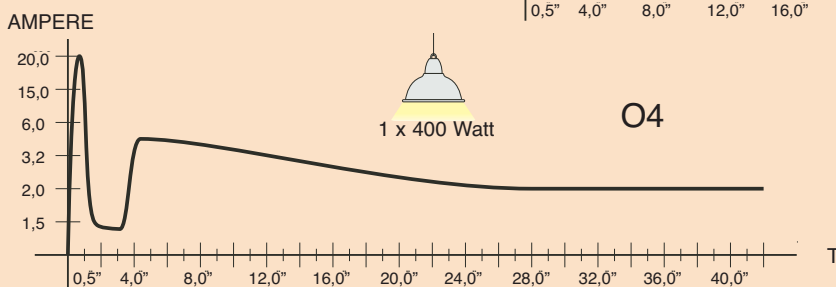
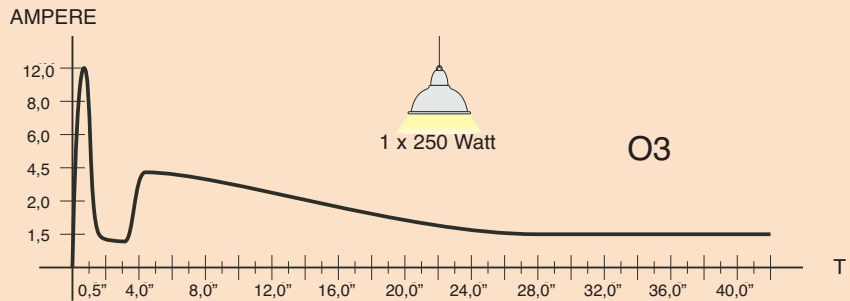
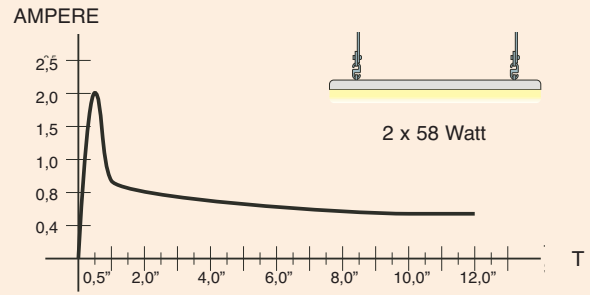
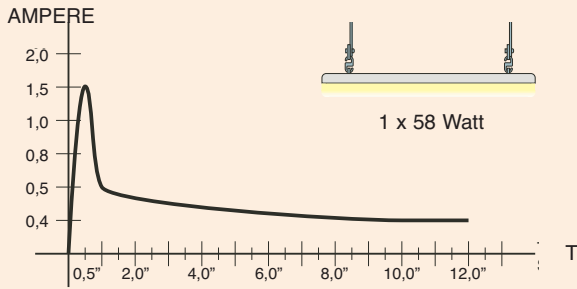

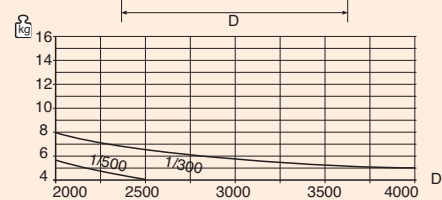
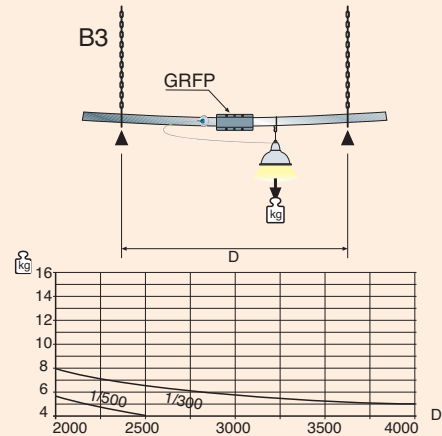
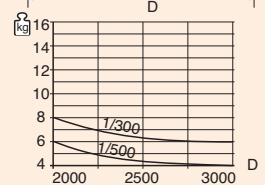
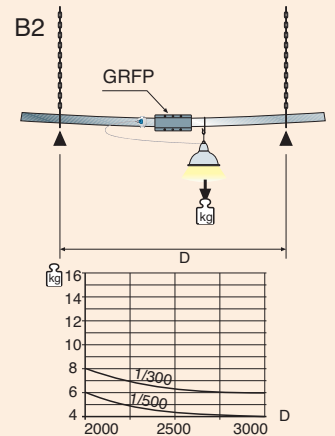
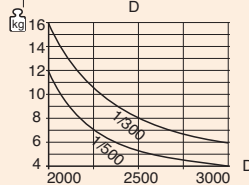
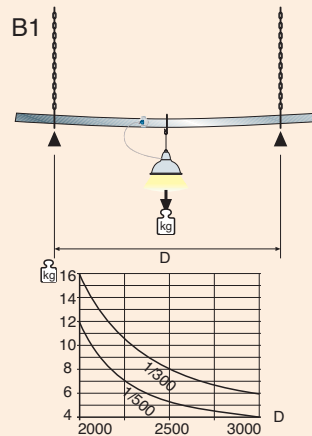
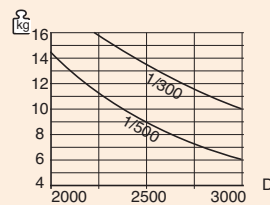
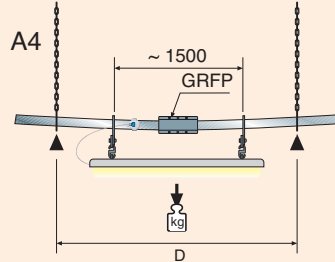
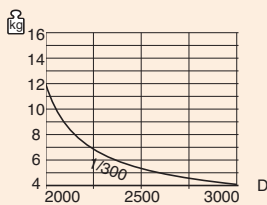
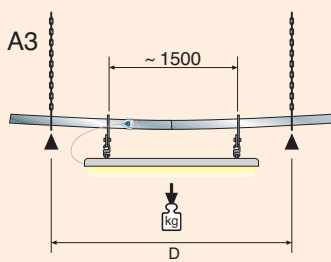
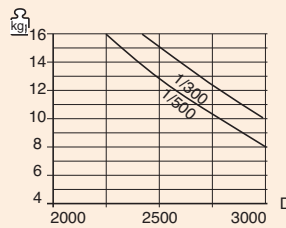
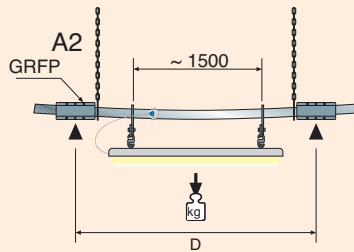
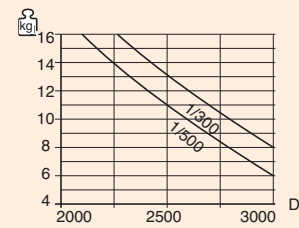
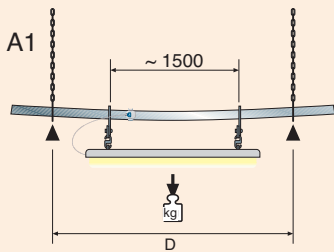
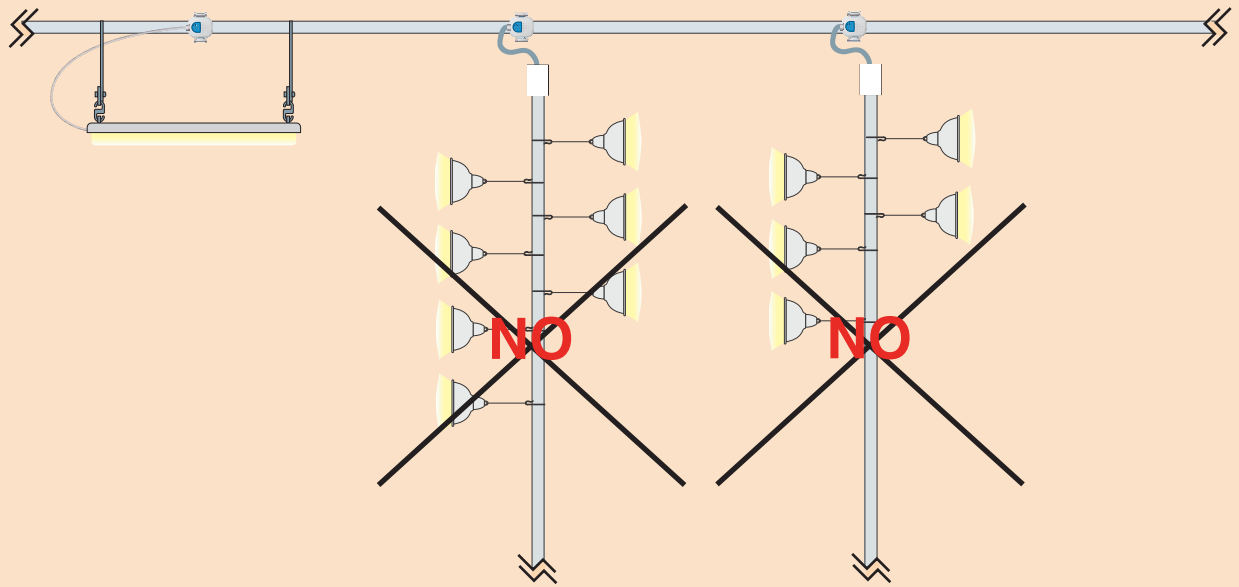

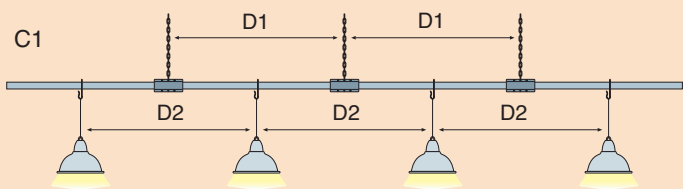

$D1 = D2$ OK

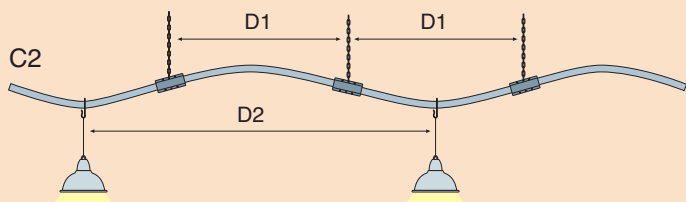

$D1 = D2$ #

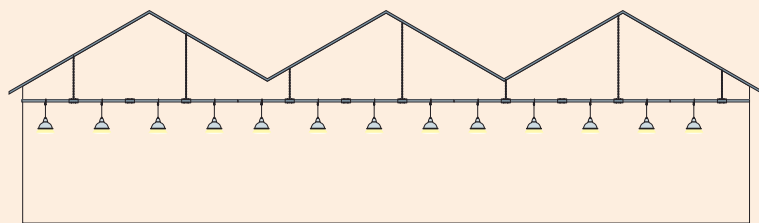
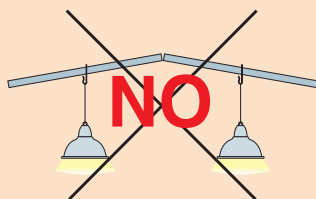
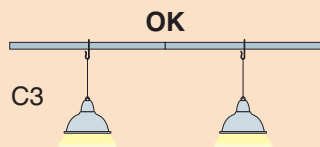

D1

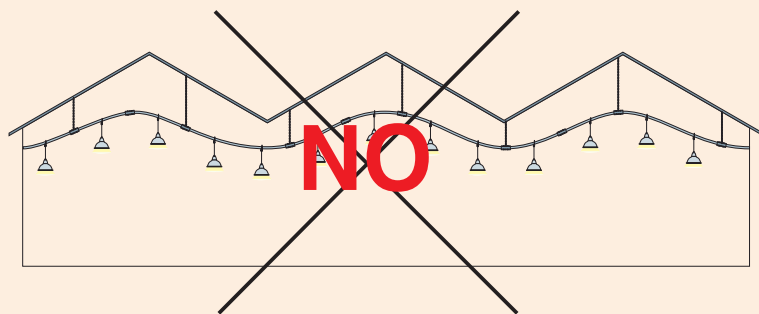

D2

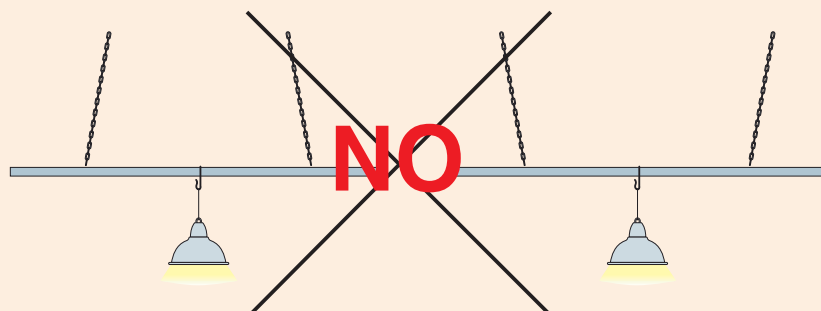
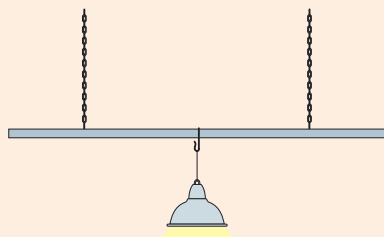

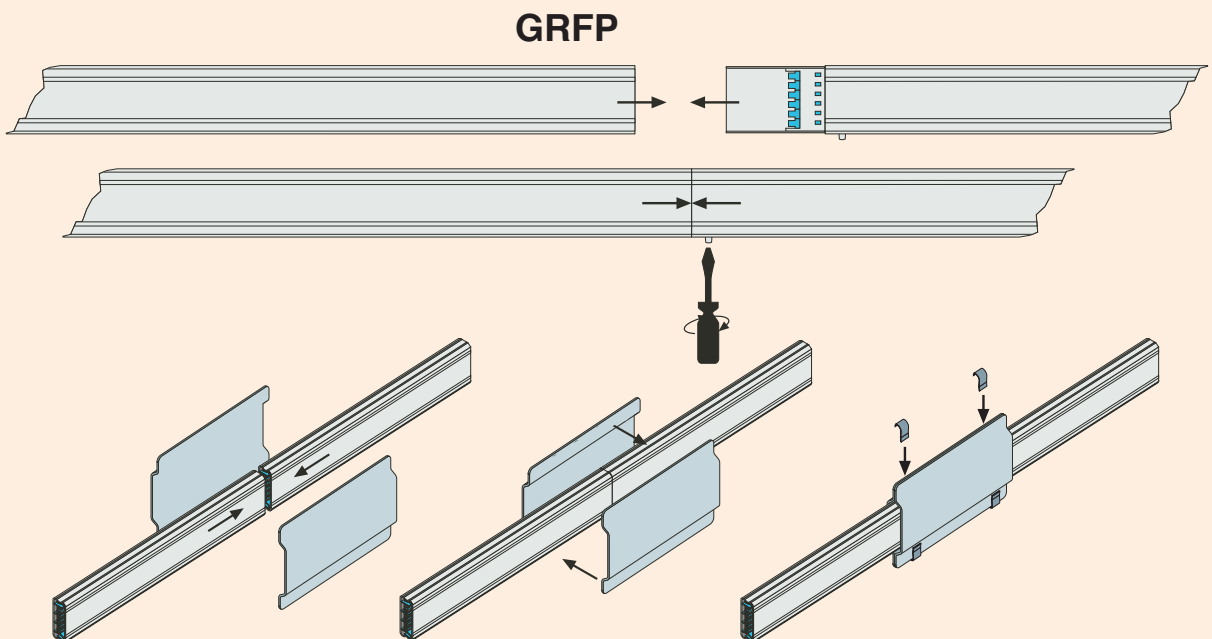
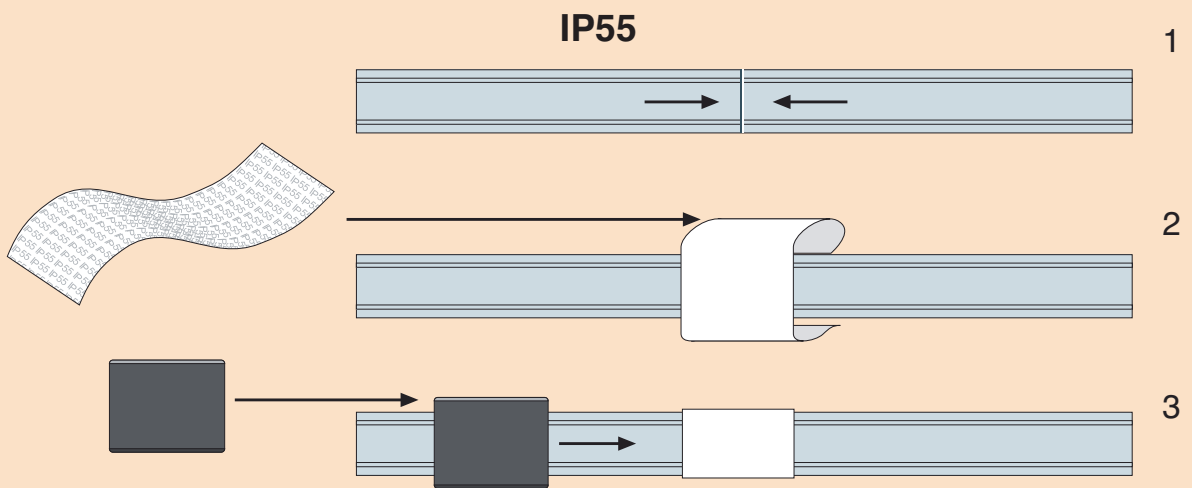
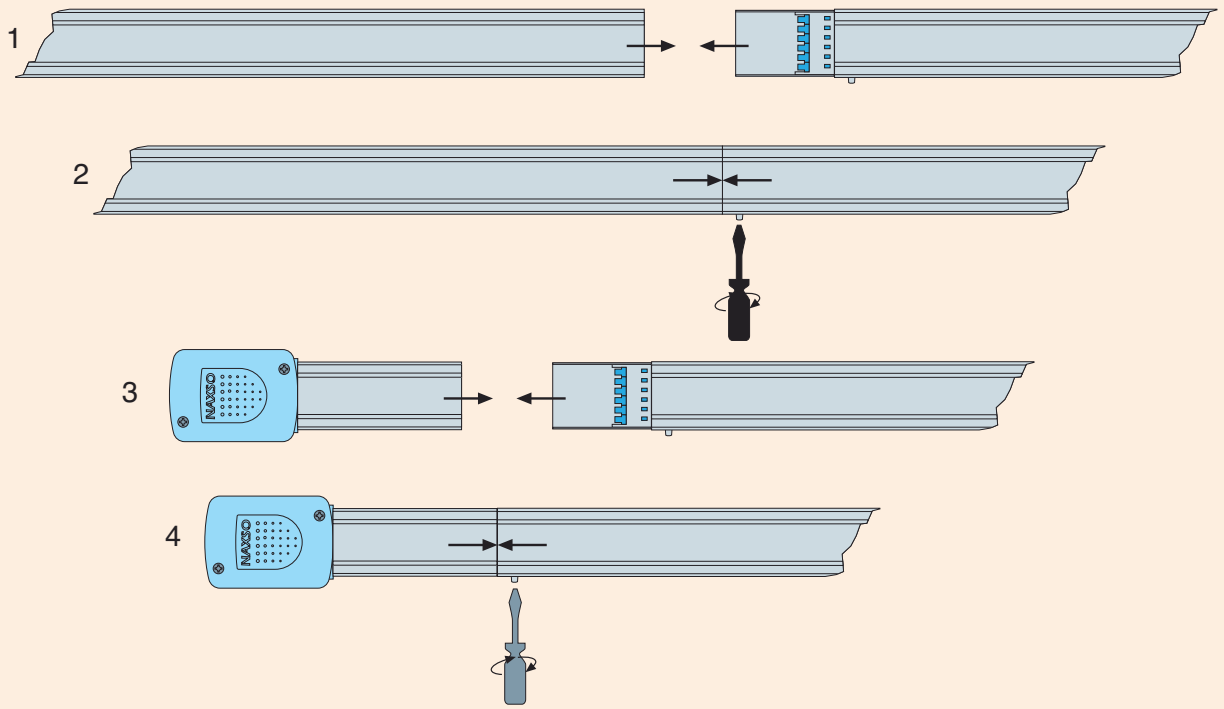

IP55 + GRFP

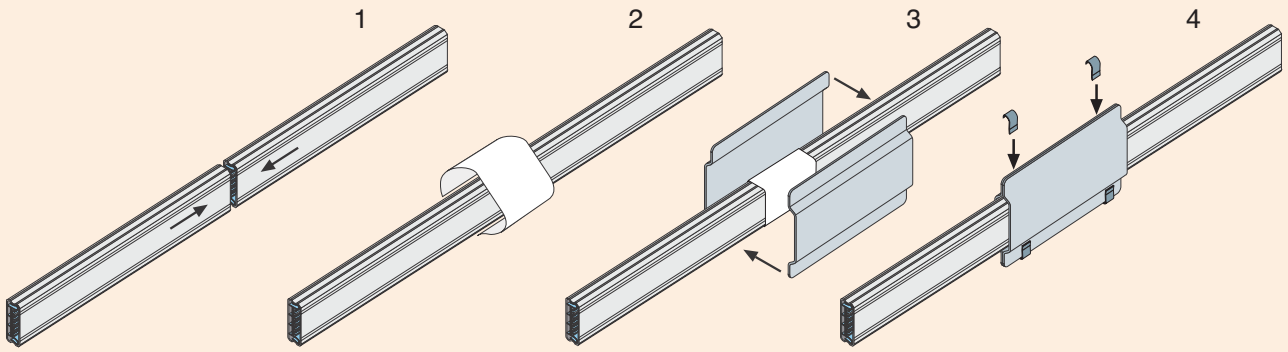

CTIP55

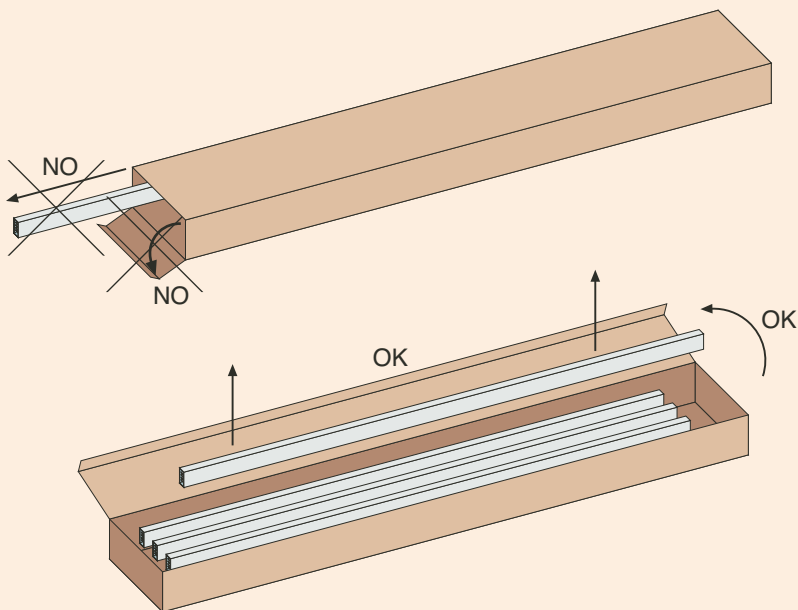
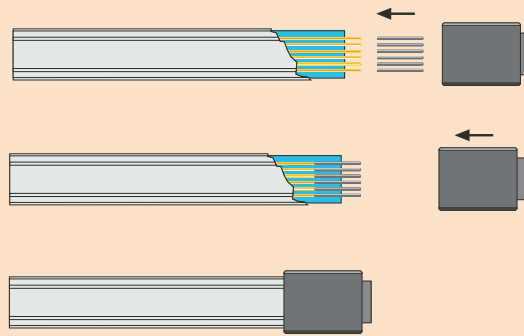

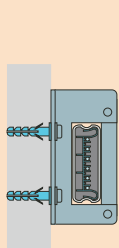
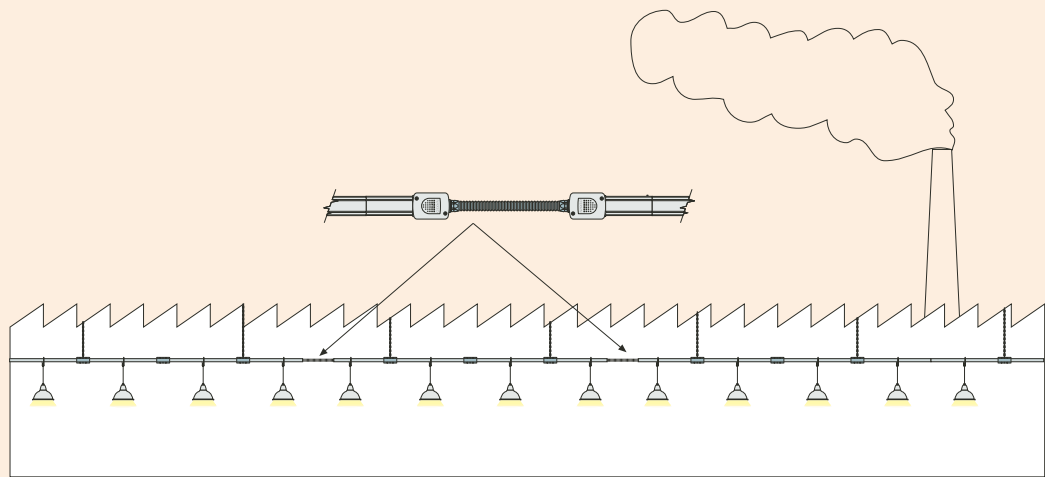
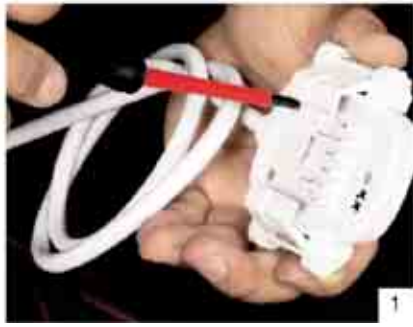

STCAP

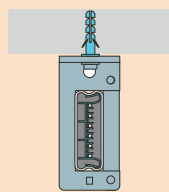

STCM

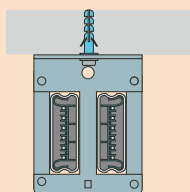

STCAD

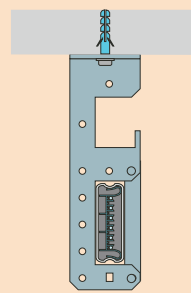

STCMC

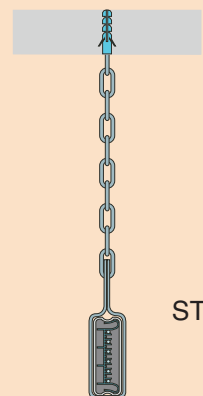

STCI

CHECK LIST

- To know what is possible what is dangerous what is to be checked.
- Naxsolux is not designed to feed power machinery in general even small.
- Naxsolux shall be working on phase–neutral or phase phase not three phase not 380 volts.
- We suggest not to feed a line or a group through a tap off as tap off is not a T.
- We suggest to overdimension lines on the basis of 30 % more than the theoretical rating. This to take into account overcurrent and losses.
- When it is possible try to install lamps next to a braket not in between two brakets to avoid flexions.
- All the tap offs shall be fitted with safety springs to ensure get them stable connected.
- After the installation all the lines shall be sturdy fixed to ceiling, straight lined up and perfectly flattened
- When a dilatation is possible due to the buiding or to other factors a flex expansion element insertion at the middle of the line every 20/30 meters is recommanded.
- When many circuits are connected the neutral shall always stay equilibrate if not a deratement shall be recommended.
- Refer to the chart in the catalogue to calculate the max number of lamps on the busbar (see page 30)
- When six conductor line is designed two of the six poles shall be derated from 25 A to 20 A from 40 A to 32 A (see pag 30).
- Check carefully the terminals size. The terminal size doesn t mean that the cable of that size shall enter the box or the tap off. Some cables are bigger than normal some are armoured some have extra insulation so the terminal size is only a reference not realted to cable. To discover if the box or the tap off have room enough for the cable please refer to the box/tap off dimensions quoted in the catalogue and not to the terminal size.
Into this catalogue there are some icons referred to the material to the insulation to the weight to the cube dimensions. The ones referred to weight and to packing dimensions are calculated including the average packing so they do not report the volume and weight of the part number but they include the average single item paking (cartoon box or envelope or plastic bag or similar) they do not include the rate referred to crates or containers).
- All the products of the catalogue are tested according to En 60439–1-2 norms.

STCA = multipurpose bracket aluminium made for ceiling or wall suspension
STCM = multipurpose bracket metal made for ceiling or wall suspension plastic side flap
STCMF = multipurpose bracket metal made for ceiling or wall suspension metal side flap
STCMC = twin bracket for busbar and plastic cable tray fully metal made for ceiling suspension
STCAP = wall bracket metal made with metal side flap Attention DO NOT INSTALL when building dilation can be possible (look at the **STCAPD** part number)
STCAPD = wall bracket for dilation installations side flap plastic made
STCMSF = metal bracket for chain suspension metal side flap
STCMSA = ceiling bracket with safety position metal side flap
STCMCV = suspension bracket metal made with screwed side flap
STCMSD = suspension bracket for chain and safety position metal side flap
STCAD = twin bracket fully metal made to install two busbars
STCMS = standard bracket for ceiling suspension plastic side flap
STCMVS = standard bracket like STCMS but fitted with safety screw
STSF = standard hook to hang chain at ceilings metal safety
STCMM = standard bracket metal made for BM busbars
STCI = standard easy suspension bracket specially designed for lamps
STM = standard multipurpose bracket for ceiling and walls
ST8 = multi purpose safety hook
STSAF = safety spring to make sure the tap off installation with lamps
STLN = multipurpose bracket to hang busbar and lamp with a **ST8** hook
STMF = multipurpose light ceiling wall bracket
GRFP = reinforce sleeve for a sturdy installation compatible with BA
GRFPM = reinforce sleeve compatible with BM
HF12EF / HF13EF = cable suspension system
TRPA/TRGA = floor turrets
EGFL = flex element installation
MDAS25001 = element to place the right distance two channels
DEPL = t element
BTIC = outlet element
MARS = joint
BXSP01 = single floor box
BXSP02... 09 = multiple box
VC = floor plastic screw to fix turrets
TAP = floor cover to close turret hole when removed